



KEENAN FILTERS®

By KTI Systems, Inc.

MK60DP SMART FILTER

“DIESEL ENGINES ONLY”

INSTALLATION/USER GUIDE

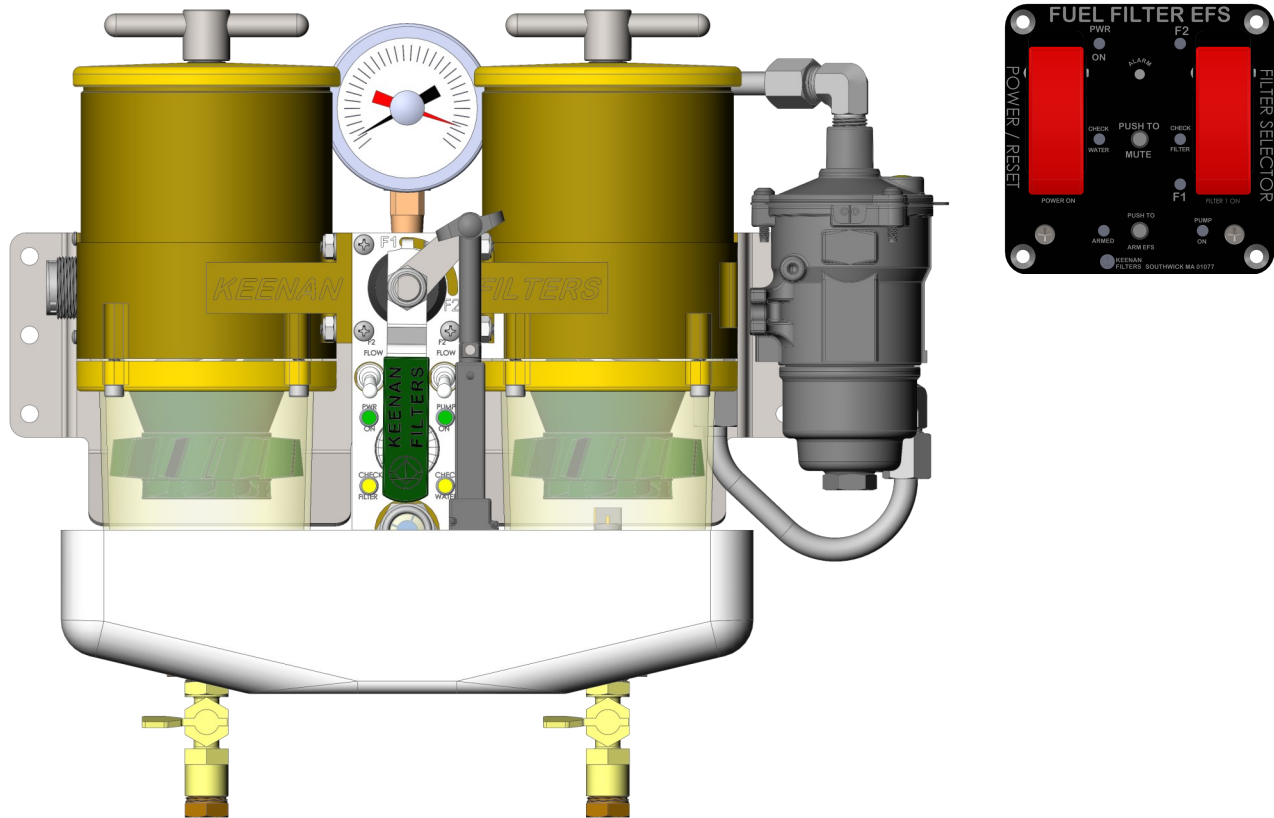

THE INSTALLATION AND SETUP SHOULD BE PERFORMED BY A QUALIFIED TECHNICIAN

US PATENTS AND PATENT PENDING, ALL RIGHTS RESERVED.

KTI SYSTEMS INC 55 HUDSON DRIVE SOUTHWICK MA 01077 (413) 569-3323 info@ktisystems.com

MADE IN USA

BENEFITS

- **GSM INTERFACE (optional)** - Allows the operator to monitor and control the engine fuel system, pumps, lights, ventilation, security etc., from any location.
- **DUAL FILTER SYSTEM** - Allows one filter online and the second ready to switch out without stopping the engine.
 - Replace the dirty filter without stopping the engine.
- **FUEL POLISHING** - Ensures clean fuel is supplied to the engine.
 - Reduces maintenance cost.
 - Allows the operator to polish the fuel quality during and after fueling and prior to starting the engine(s)
 - Gives the operator a solution to fuel contamination.
- **ELECTRIC FILTER SWITCH (EFS)** - Allows the operator to switch filters from the remote panel or can be armed to switch filters automatically when the filter starts to clog or there is high water.
- **REMOTE WARNING PANEL** - Alerts the operator before fuel problems can affect engine operation.
 - Can be installed anywhere in a facility or vessel.
- **ADVANCE WARNING** – Allows the operator to use a lower micron pre-filter for cleaner engine fuel delivery.
- **EARLY CLOGGING FILTER AND WATER DETECTION** – Water and contaminants are most often the reasons why diesel engines inadvertently shut down.
- **BACK-UP FUEL PRESSURE** - Backs up the engine lift pump if it starts to fail. Allows for faster system bleeding.
- **SYSTEM TESTING** - Allows the operator to test the system for indication and integrity before operation or after maintenance has been performed.
- Uses genuine Racor® elements 

STANDARD FEATURES

	Keenan Filters® MK60DP/K60DP	Other Filters
GSM interface (optional)	✓	-
Dual filters	✓	?
Fuel polishing	✓	-
Electric Filter Switch (EFS optional)	✓	-
Quick system bleeding	✓	-
Back-up fuel pressure for engine lift pump	✓	-
Remote advance warning panel	✓	-
Clogging filter detection and warning	✓	?
Water detection and warning	✓	?
System testing	✓	-
Water drain valve	✓	?
Spill shield/heat shield	✓	?
Inlet shut-off valve	✓	-
Top loading	✓	?
Vacuum gauge	✓	?

MK60DP INSTALLATION/ USER GUIDE

TABLE OF CONTENTS

PAGE	DESCRIPTION
1.	MK60DP with EFS EXPLODED VIEW
2.	INSTALLATION TIPS
3.	FUEL DIAGRAMS
5.	MOUNTING PANEL DIMENSION DIAGRAM
6.	WIRING INSTALLATION TIPS
7.	MOUNTING LOCATIONS & CONNECTIONS
8.	MK60DP (without EFS) KH6010 ELECTRICAL CONNECTIONS
8.	KP300 INSTALLATION
9.	KP300 PANEL CUTOUT TEMPLATE
10.	MK60DP (without EFS) KH6010 WIRING DIAGRAM
11-12.	FIELD WIRING (without EFS) / GSM CONNECTIONS
13.	MK60DP <u>with EFS</u> KH6060 ELECTRICAL CONNECTIONS
13.	KP600 INSTALLATION
14.	KP600 PANEL CUTOUT TEMPLATE
15.	MK60DP <u>with EFS</u> KH6060 WIRING DIAGRAM
16-17.	FIELD WIRING <u>with EFS</u> / GSM CONNECTIONS
18.	SPECIFICATIONS
19.	POST INSTALLATION SERVICE AND OPERATIONAL CHECK
20.	FILTER ELEMENT REPLACEMENT
21.	DRAINING WATER FROM BOWL
22.	KP300 & KP600 CONTROL PANEL OPERATION
23.	HOW IT WORKS
25	FUEL POLISHING
	WARRANTY

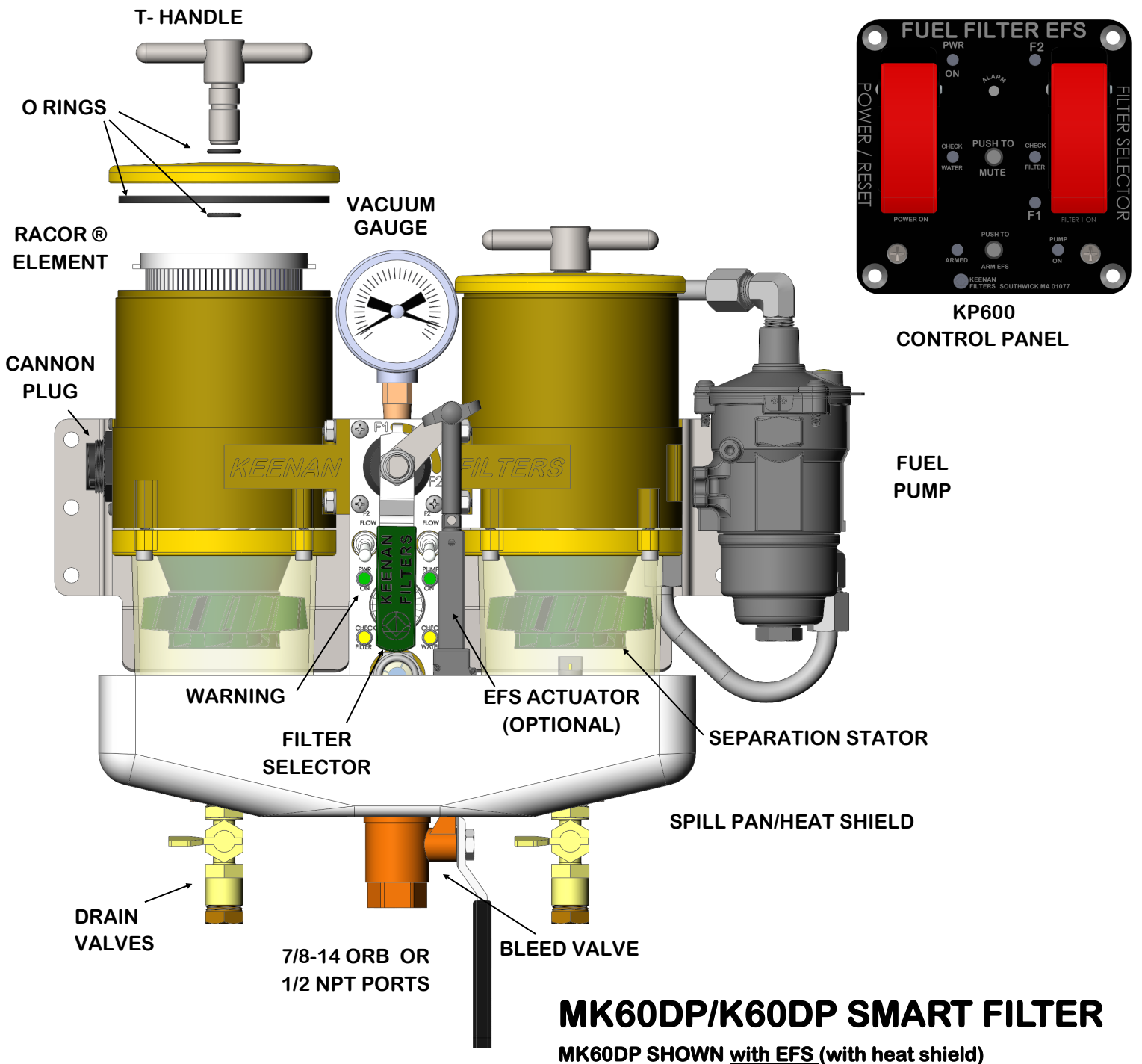

MK60DP/K60DP SMART FILTER
 MK60DP SHOWN with EFS (with heat shield)

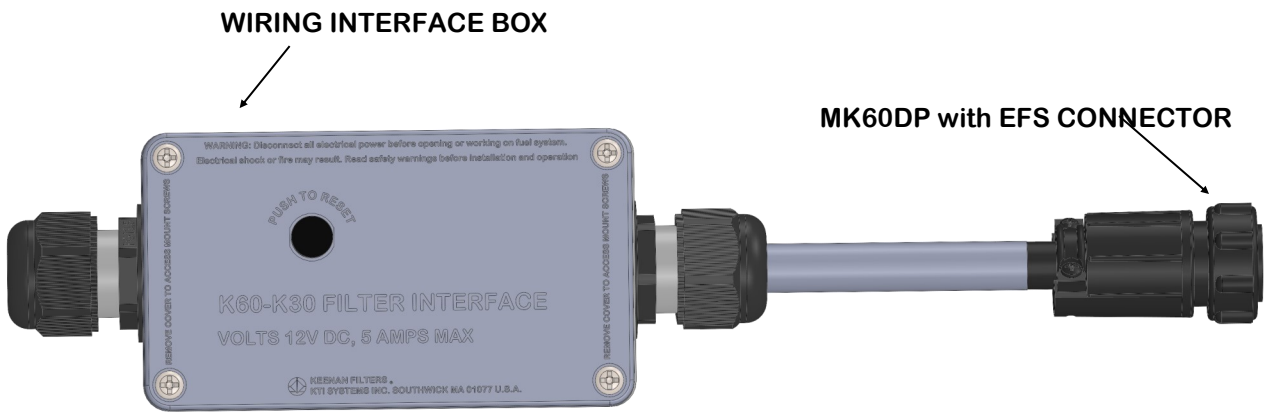

KH6060 INTERFACE CABLE ASSEMBLY

THE INSTALLATION AND SETUP SHOULD BE PERFORMED BY A QUALIFIED TECHNICIAN

INSTALLATION TIPS

PLEASE READ BEFORE INSTALLING

- Do not smoke or allow open flames.
- Turn off engine.
- Turn off power and disconnect battery ground cable connection.
- Before drilling holes or installing mounting hardware make sure the back side is clear of obstructions such as fuel lines, electrical harnesses, fuel and fluid tanks, ships hull, etc.
- Use proper fuel lines, connections and mounting hardware. Use proper wire, connectors and routing.

SUGGESTED TOOLS AND SUPPLIES

- Shop towels and a clean bucket.
- Clean diesel to prime the filter.
- Clean engine oil to lubricate seals.
- Proper thread sealant (do not use thread tape).
- Use adequate light, ventilation and eye and skin protection.
- Proper 16 AWG wire for harness or 10 conductor 16 AWG cable (KTI P/N KW1216 or KW1416 optional)
- Additional Check Valve (KTI P/N KA159CV optional)

FUEL SYSTEM DESIGN AND LAYOUT

The MK60DP/K60DP is installed as a primary filter. This system allows for one filter to be online and the other is serviced and can be switched online at anytime. The MK60DP/K60DP also incorporates an integrated fuel pump that allows the operator to polish fuel, bleed the fuel system, back up fuel for the engine lift pump and can port fuel back to the offline filter for servicing. Listed below are some basic fuel systems, but it is still the operator, designer and the installers responsibility to configure the system properly. THE DIAGRAMS ARE FOR REFERENCE ONLY

SINGLE ENGINE SINGLE TANKS

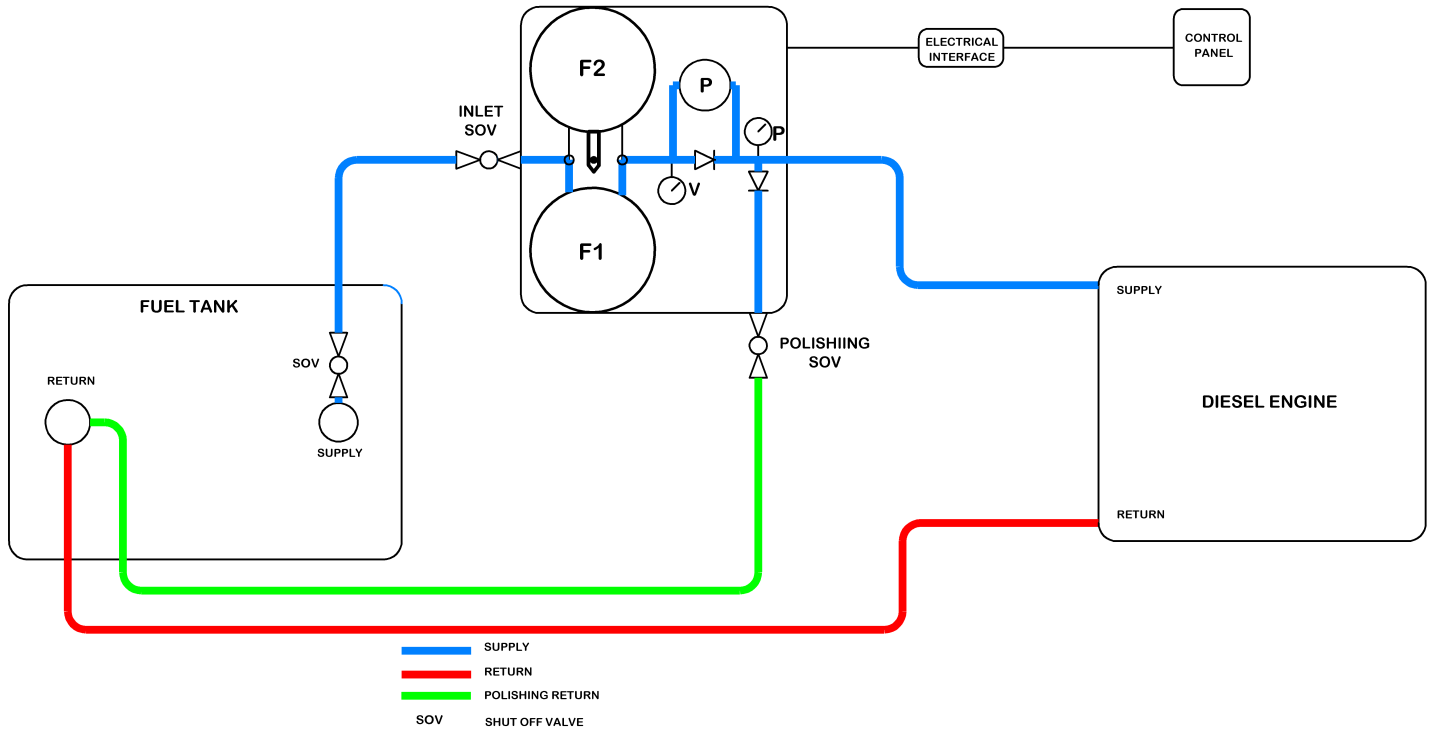

SINGLE ENGINE DUAL TANKS

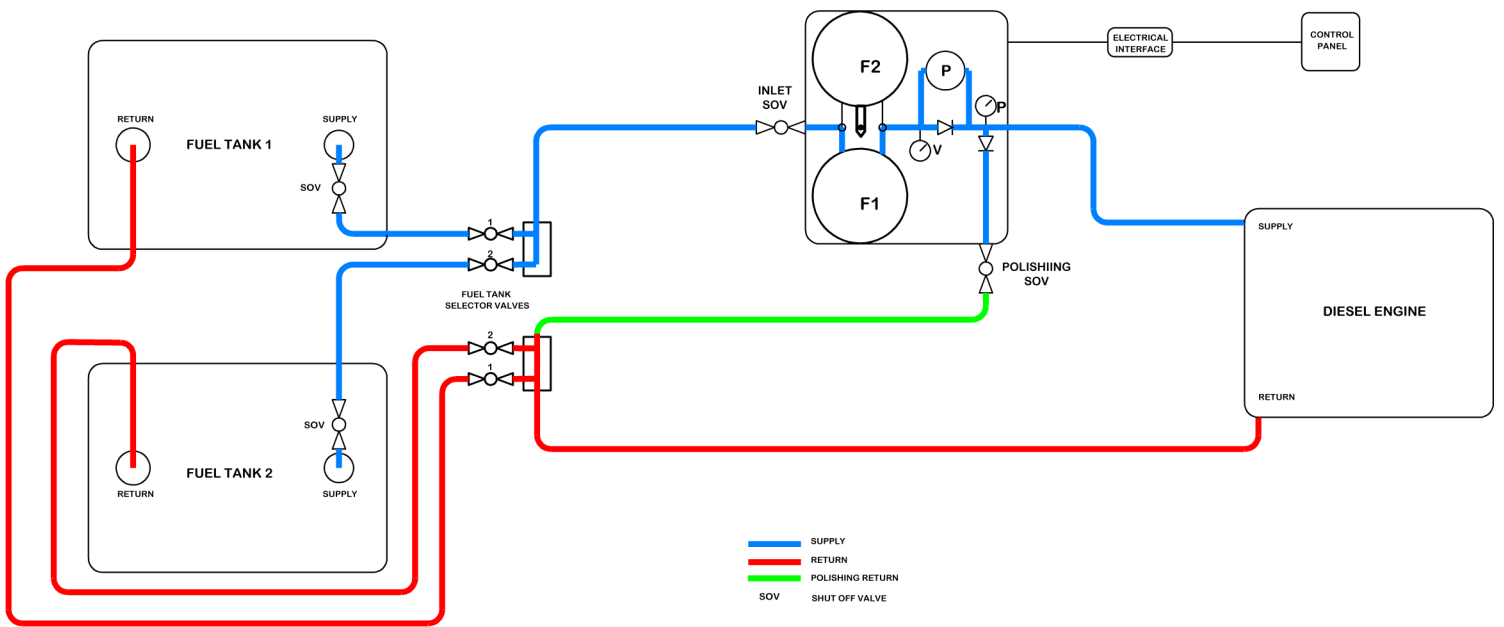

K60D, DP MOUNTING PANEL DIMENSIONS

NOT TO SCALE

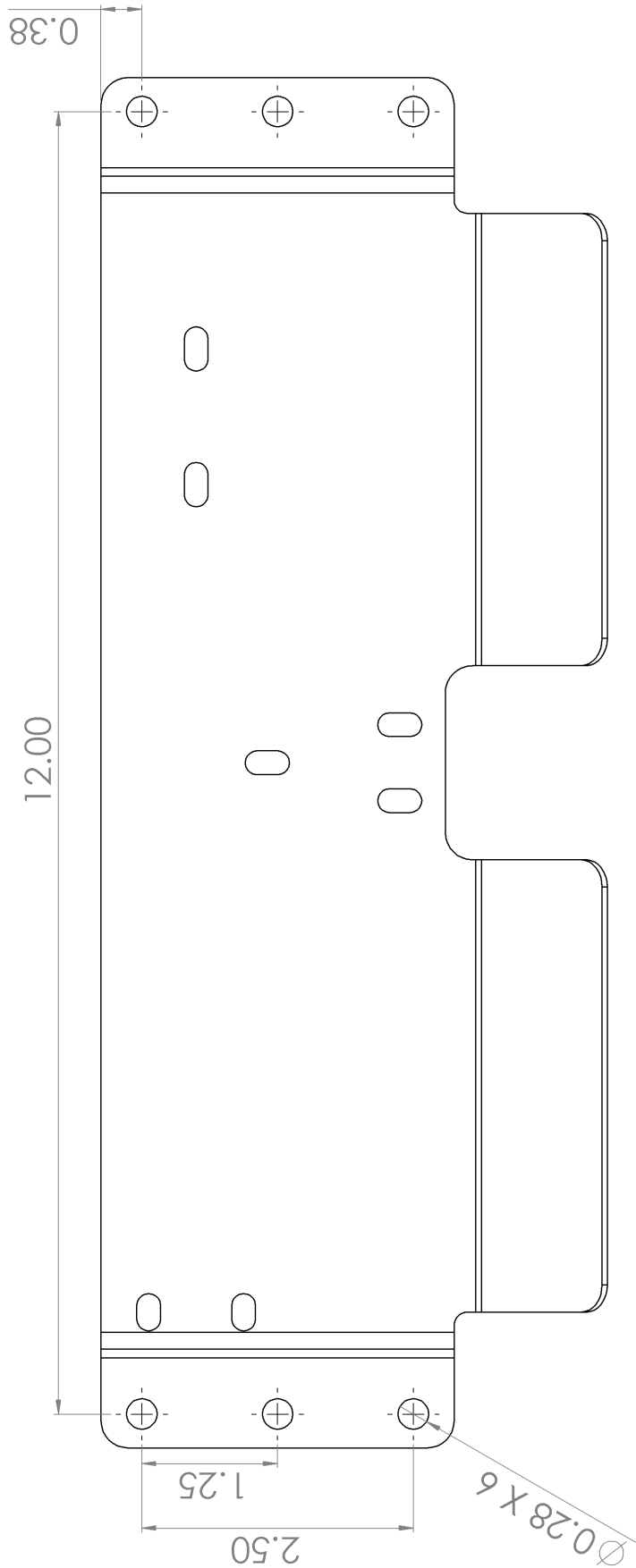

PROPERTY AND CONFIDENTIAL THIS DRAWING IS THE SOLE PROPERTY OF KTI SYSTEMS INC. ANY REPRODUCTION IN PART OR AS A WHOLE WITHOUT THE WRITTEN PERMISSION OF KTI SYSTEMS INC. IS PROHIBITED.		UNLESS OTHERWISE SPECIFIED: DIMENSIONS ARE IN INCHES FRACTIONALS: 1/32 DECIMALS: 0.0005 TWO PLACE DECIMAL ±0.01 THREE PLACE DECIMAL ±0.004		NAME AK	DATE 7/17/17	KTI SYSTEMS INC. 2007MCK, WA.	
UNLESS OTHERWISE SPECIFIED OBTAIN GEOMETRY FROM CAD MODEL CONSIDER ALL DIMENSIONALLY UNDEFINED FEATURES CAD AND PROCESS DRIVEN		DRAWN CHECKED ENG APPR. MFG APPR. G.A.		TITLE: MOUNTING PANEL		SIZE B	DWG. NO. K60136 MOUNTING PANEL DIMS
MATERIAL 300 SERIES SS		FINISH		COMMENTS:		SCALE: 1:1	WEIGHT:
DO NOT SCALE DRAWING						SHEET 1 OF 1	REV A

WIRING INSTALLATION TIPS

1. The MK60DP *without* the EFS will use the KP300 control panel and the KH6010 interface box.
2. The MK60DP *with* the EFS will use the KP600 control panel and the KH6060 interface box.
3. Field connections are made between the KH6060 or KH6010 interface box terminals and the KP300 or KP600 remote control panel terminals. Both units have printed circuit boards (PCB) with installed Euro type* terminal blocks. This makes the connections simple to make. The system voltage is 12 VDC. If it is being installed into a 24 volt system use a 24 to 12 volt DC inverter with at least a 5 amp load capacity.

**SERVICE NOTE: Euro type blocks are very common and user friendly, but simple mistakes can make you spend time trouble shooting. One of the most common mistakes is not stripping enough insulation off of the termination end. When this happens, the insulation gets clamped not the conductor. Another common mistake is loose strands shorting to the adjacent clamping yoke (wire socket).*

4. Use approved 16 AWG wire and strip 3/16" to 1/4" of insulation off on the termination end. Make sure the yolk screw is backed out and the yolk cavity is clear. Push the wire in until it bottoms and hold the wire in position when tightening the yolk screw. After tightening, pull on the connection to test, then retighten if needed. Visually inspect to make sure all the strands are clamped in the yolk clamp and the conductor is barely visible.

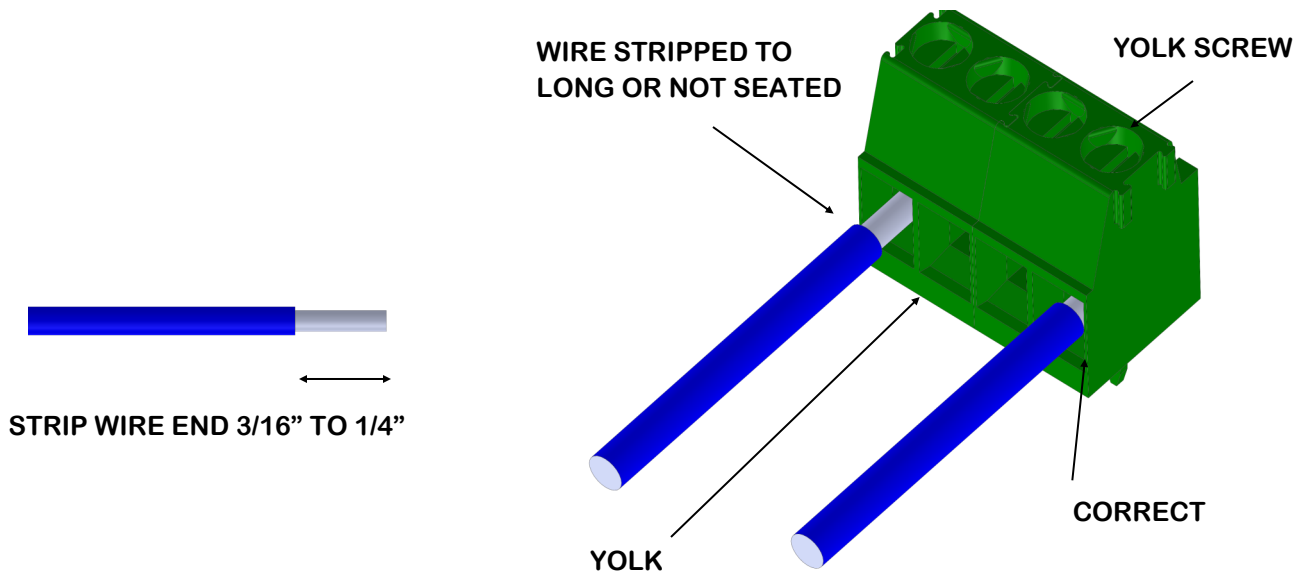

MK60DP MOUNTING LOCATION

1. The filter assembly should be installed between the fuel tank (fuel source) and the suction side of the engine lift or transfer pump. Pre-existing filters should be removed. If the engine manufacturer has permanently installed primary filters, service with new filter elements.
2. The filter assembly is be mounted between the horizontal plane of the engine lift or transfer pump inlet and the bottom of the fuel tank. The filter must be mounted in a vertical position on a structure that is also vertical (DO NOT MOUNT ON ENGINE) with the Tee-handle on top. Enough space should be left above and below the unit to service the filter. Allow about 5" above the filter to remove and replace the filter element and at least 2" below to drain the filter. USE APPROPRIATE MOUNTING HARDWARD
3. A shut off valve is installed in the inlet side of the filter, which will allow for system testing. If the fuel tank (fuel source) is located close to the filter, the fuel tank supply shut off may be used.
4. If the fuel tank (fuel source) is mounted higher than the filter, a shut off valve must be installed into the inlet of the filter assembly. This will stop the flow of fuel when servicing the filter or fuel system.
5. This systems has a polishing port that allows clean fuel to be ported back to the tank, this port has a shut off valve for control of the flow.
6. Location of the filter should allow for easy access while servicing and away from anything that can injure the operator, such as hot and/or moving equipment.
7. Use appropriate fuel line with the least amount of restriction, such as 3/8" to 1/2" hose or ridged line to supply the MK60DP/K60DP. Avoid sharp 90 degree bends. Route fuel lines away from sharp objects and heat. *Note: if sharing the engine return line, use 3/8" ID minimum to reduce back pressure.*

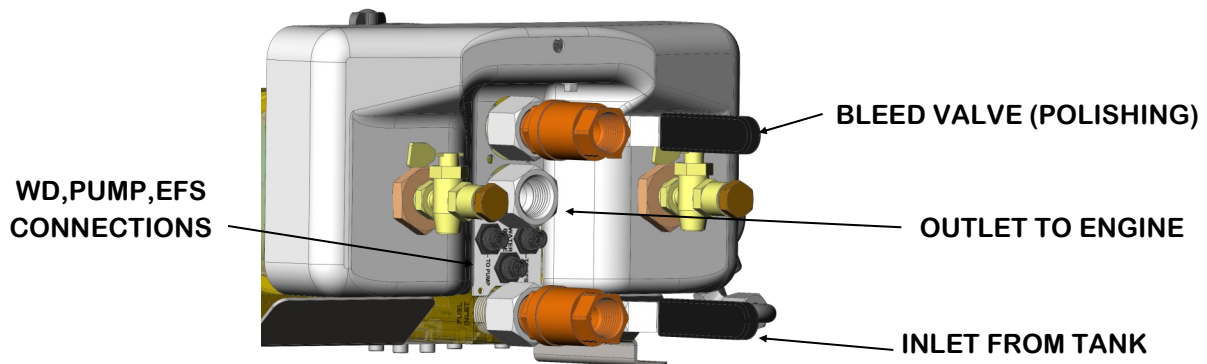
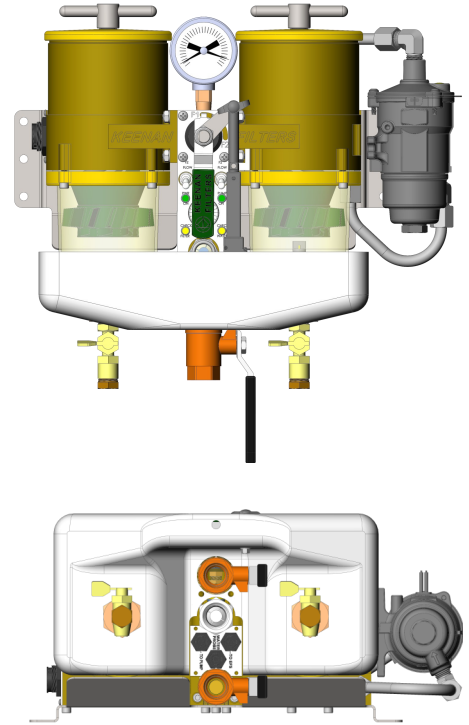

MK60DP CONNECTIONS

1. The MK60DP inlet, outlet and polishing port connections are 7/8-14 ORB or 1/2" NPT (using supplied ORB to NPT adapters). If using the supplied shut off valve the port is a 1/2" NPT. Use approved 3/8" or 1/2" fuel line and connectors. To reduce restrictions, limit the amount of 90 degree connectors or sharp bends. Make sure fuel lines are supported and keep fuel lines away from sharp and hot objects.
2. The KH6010 or KH6060 (EFS) cable assembly is factory connected and is positioned on the left side of the filter.
3. To mount the interface box remove the 4 cover screws and cover. Depending on the wire run, position the interface box either horizontally or vertically against the vertical surface. Mark the 2 mounting holes, drill holes for hardware and mount box.

MK60DP ELECTRICAL CONNECTIONS (without EFS)

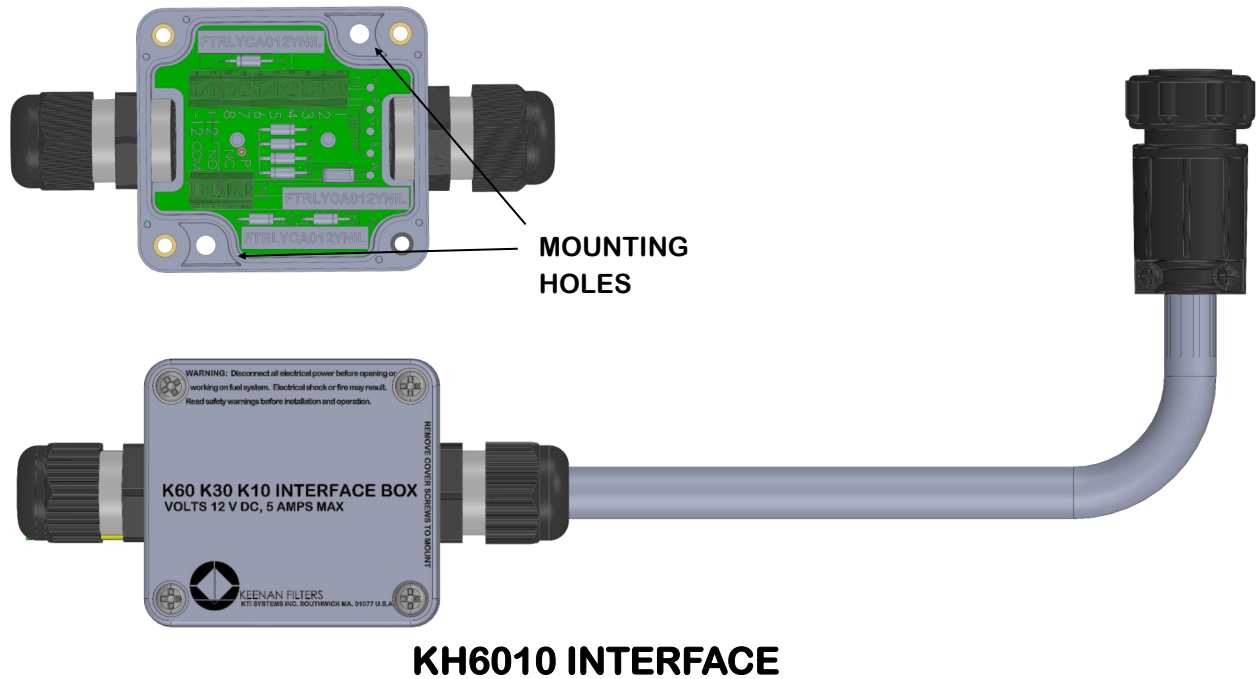

KP300 REMOTE PANEL INSTALLATION

1. The KP300 is the remote panel designed to give the operator indication of both water and high vacuum (filter clogging), with warning lights and an audible tone. The panel should not be exposed to outside elements and must be mounted inside. Make sure the surface is flat, easily accessible and not in an area that will be bumped, kicked or objects placed on it. Determine that when routing wire from the KP300 panel to the interface box, it can be done easily with minimal obstructions.
2. The cutout template is only a guide. When printing out the KP300 template on PAGE 8 make sure the printer settings are set to 100% scale and use the document margins. After printing, measure the template and confirm the template is to scale. The final drill and cut dimensions are the installers responsibility to check.
3. Temporarily Install the KP300 panel and secure with #6 flat screws. Make sure the panel is flat and the screw fit flush, then remove panel for wiring.



KP300 CONTROL PANEL

1

2

B

B

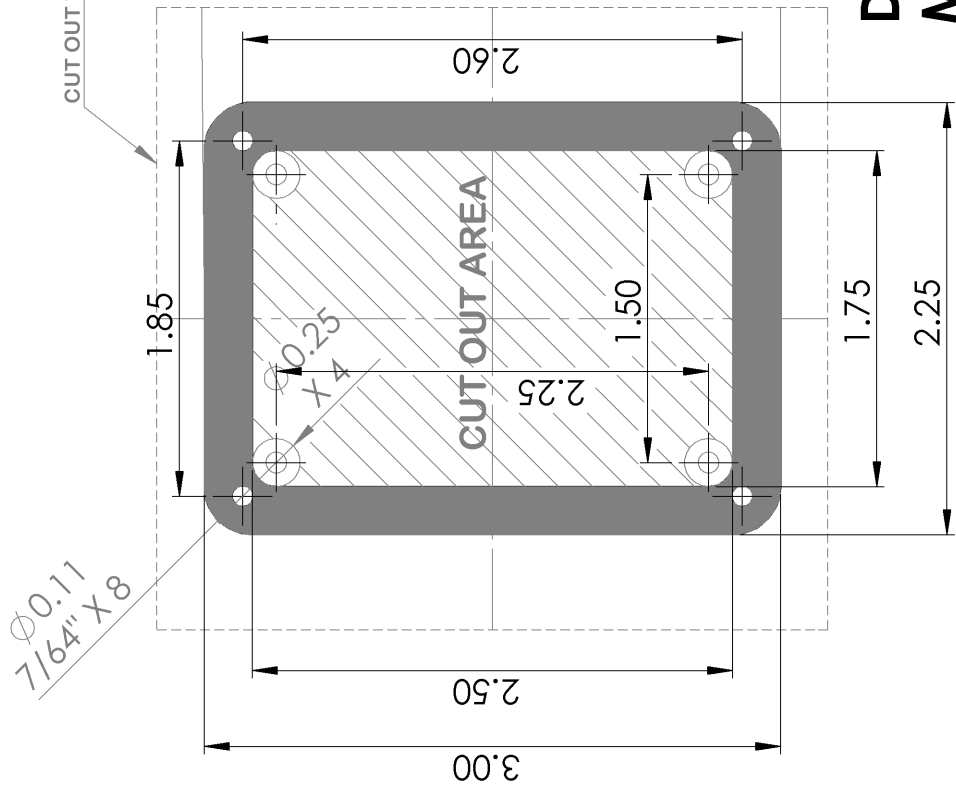

CUT OUT TEMPLATE ON DOTTED LINE

1. CUT OUT TEMPLATE ON DOTTED LINE.
2. ALIGN TEMPLATE ON A SURFACE TO WHICH THE KP300 PANEL WILL BE MOUNTED.
3. MAKE SURE THERE IS CLEARANCE BEHIND MOUNTING AREA.
4. SECURE TEMPLATE WITH TAPE.
5. CENTER PUNCH AND DRILL 8 X 7/64(.109)" HOLES.
6. DRILL OUT THE 4 INSIDE 1/4(.25)" HOLES.
7. CUT OUT CENTER SECTION (HATCHED AREA).
8. DEBUR AND CLEAN EDGES.
9. REMOVE TEMPLATE AND CHECK KP300 PANEL FIT.

DO NOT SCALE WHEN PRINTING USE 1:1
MEASURE TEMPLATE BEFORE USING

A

A

UNLESS OTHERWISE SPECIFIED OBTAIN GEOMETRY FROM CAD MODEL CONSIDER ALL DIMENSIONALLY UNDEFINED FEATURES CAD AND PROCESS DRIVEN		UNLESS OTHERWISE SPECIFIED: DIMENSIONS ARE IN INCHES TOLERANCES: FRACTIONAL: 1/32 ANGULAR: ±0.5° TWO PLACE DECIMAL ±0.01 THREE PLACE DECIMAL ±.004	DRAWN AK	DATE 5/17/17	KTI SYSTEMS INC. <small>SOUTH/OK, MA.</small>
NEXT ASSY USED ON		INTERPRET GEOMETRIC TOLERANCING PER: MATERIAL	CHECKED	ENG APPR. MFG APPR.	TITLE: KP300 CUT TEMPLATE
APPLICATION		FINISH	REV		
DO NOT SCALE DRAWING		COMMENTS:	SIZE A	DWG. NO. KP300CUTTMP	SCALE: 1:1 WEIGHT: SHEET 1 OF 1

PROPRIETARY AND CONFIDENTIAL
 THE INFORMATION CONTAINED IN THIS
 DRAWING IS THE SOLE PROPERTY OF
 KTI SYSTEMS INC. ANY REPRODUCTION
 IN PART OR AS A WHOLE WITHOUT THE
 WRITTEN PERMISSION OF KTI SYSTEMS INC.
 IS PROHIBITED.

1

2

MK60DP WIRING DIAGRAM

(without EFS)

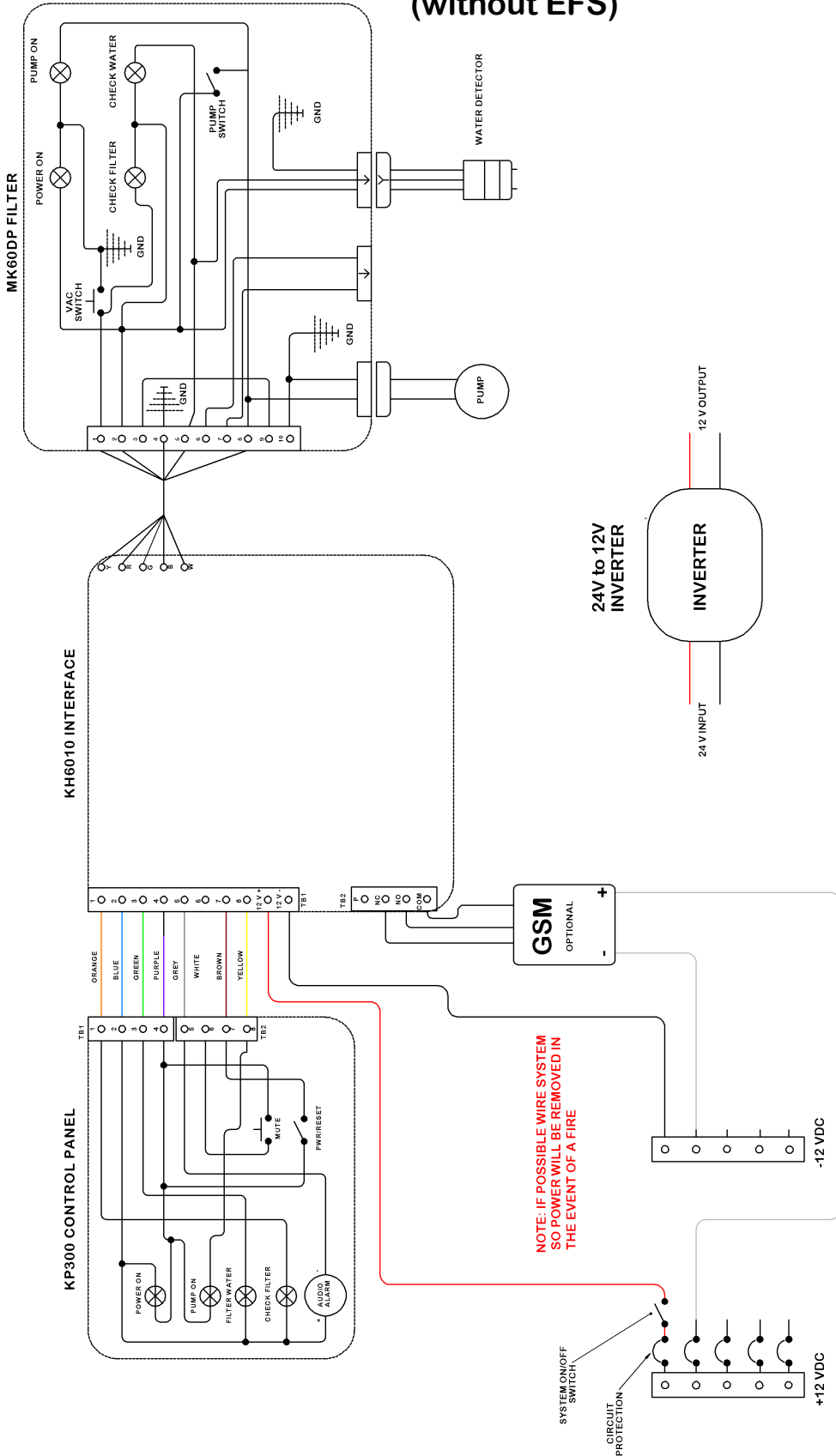

KT SYSTEMS INC.
SOUTHWICK, MA

DATE	NAME	DATE
3.15.17	AT	3.15.17

VALUES APPLY AFTER ANY SURFACE TREATMENTS

ORANGE MEANS FROM CAD MODEL UNLESS NOTED OTHERWISE. ALL UNLESS NOTED OTHERWISE.

DO NOT SCALE

REVISIONS:

NO.	DESCRIPTION	DATE
1	ISSUED FOR CONSTRUCTION	3.15.17

SEE DWG. NO. **D**

FIELD WIRING (without EFS)

(Please read before wiring)

The MK60DP field wiring can be broken down to 2 systems:

1. INTERFACE WIRING - KH6010 Interface to the KP300 Control Panel
2. GSM INTERFACE (Optional) – Warning and Pump control

INTERFACE WIRING

1. Referencing the MK60DP wiring diagram, a small harness of 8 communication wires plus 2 circuit protected 12 vdc power and ground wires need to be routed between the KP300 panel and the KH6010 interface box. (Use a on/off switch to control system power or use the circuit breaker)
2. Fabricate a 10 wire harness using approved 16 awg wire or purchase our cable assembly P/N KW1016 by the foot. TO SIMPLIFY THE INSTALLATION MAKE THE HARNESS/CABLE TO INTERFACE BOX CONNECTIONS PRIOR TO INSTALLING THE HARNESS OR CABLE ASSY SEE PAGE 12.
3. Start making the connections at the KH6010 interface if not already done. Install the cable into the cable gland 6-10” strip back the insulation jacket 3-1/2” now pull the cable back so only 3-1/2” of wires are showing. Start your connections closest to the cable gland and out -12,+12, 12 -1 etc. Continue with wiring the KP300 panel

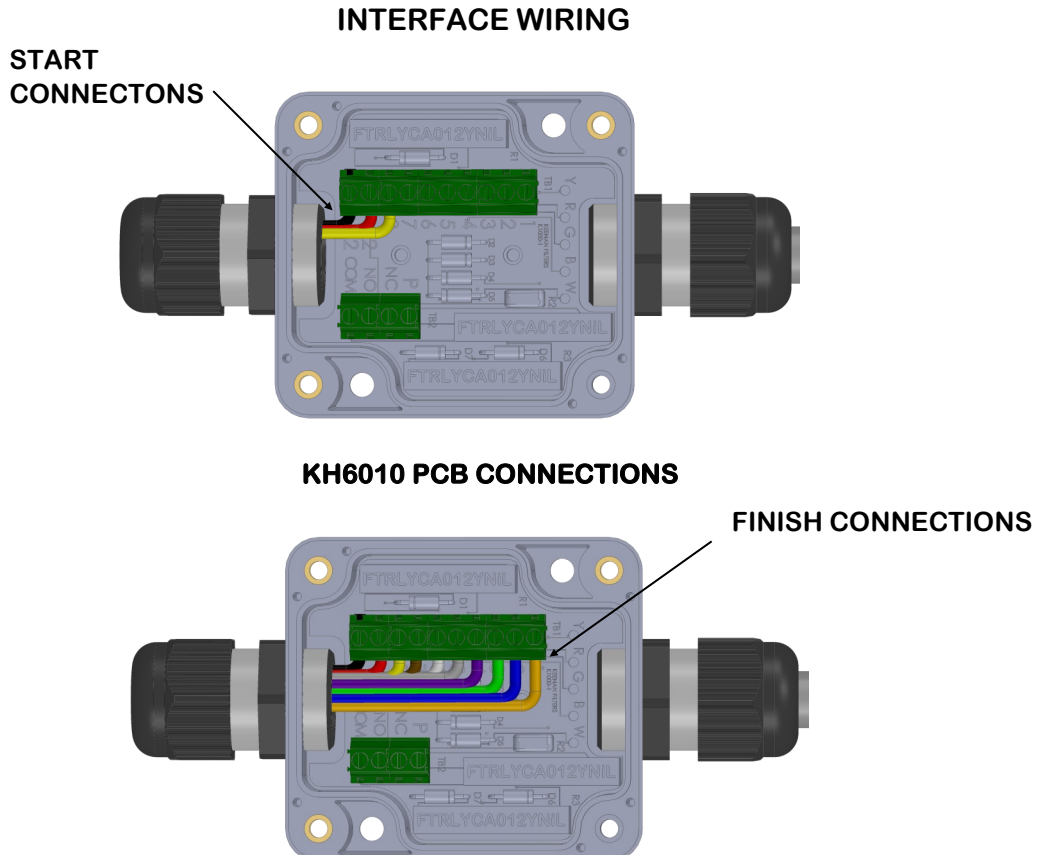

FIELD WIRING (without EFS) - continued

4. Connect the KP300 control panel to the wiring harness and also the 12 VDC circuit protected power. Inspect and recheck all connections, check that wire harness and connections are supported and away from hot or moving equipment.

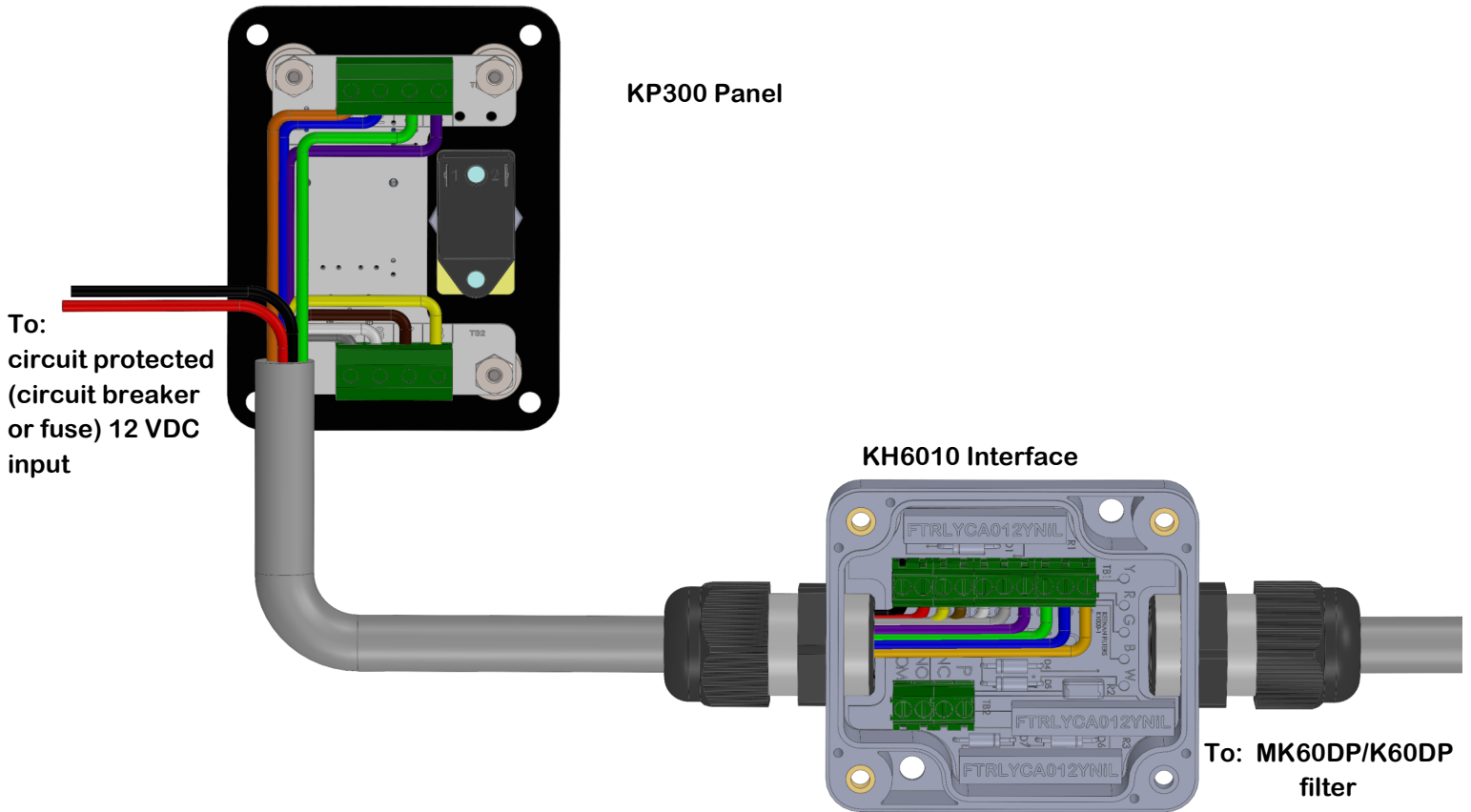

WIRE COLORS CAN BE INSTALLERS CHOICE

KP300 CONTROL PANEL CONNECTON		KH6010 INTERFACE CONNECTION	CIRCUIT PROTECTED 12 VOLT SUPPLY		KH6010 INTERFACE CONNECTION
1 YELLOW	CONNECTS TO	1 YELLOW	+12 RED	CONNECTS TO	+12
2 BLUE	CONNECTS TO	2 BLUE	-12 BLACK	CONNECTS TO	-12
3 GREEN	CONNECTS TO	3 GREEN	WARNING: REVERSE POLARITY MAY DAMAGE INTERNAL CIRCUITS	MAX CURRENT 2.3 AMPS- WIRE RUN SHOULD BE LESS THAN 15 FEET, IF LONGER USE A LOWER WIRE GAUGE CONDUCTOR AND TERMINAL BLOCK.	
4 PURPLE	CONNECTS TO	4 PURPLE			
5 GREY	CONNECTS TO	5 GREY			
6 WHITE	CONNECTS TO	6 WHITE			
7 BROWN	CONNECTS TO	7 BROWN			
8 ORANGE	CONNECTS TO	8 YELLOW			

GSM INTERFACE (optional)

1. The auxiliary connections provide a normally open “NO” or normally closed “NC” contacts, with a common connection “COM”. The connections are intended for the KTI GSM communicator. This system will warn the operator if the filter is clogging or water is present via a message sent on either a cell phone or by email. This system also allows the customer to turn on a device remotely from a mobile device or computer. Please refer to the GSM installation guide for the interface wiring.

MK60DP ELECTRICAL CONNECTIONS

with optional EFS

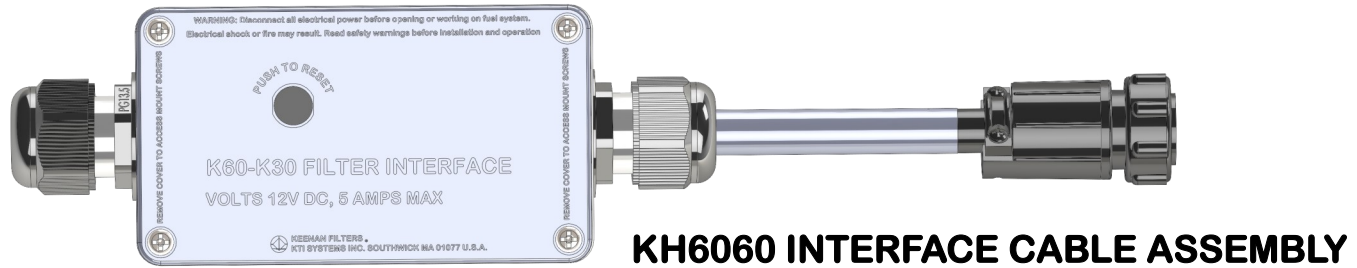
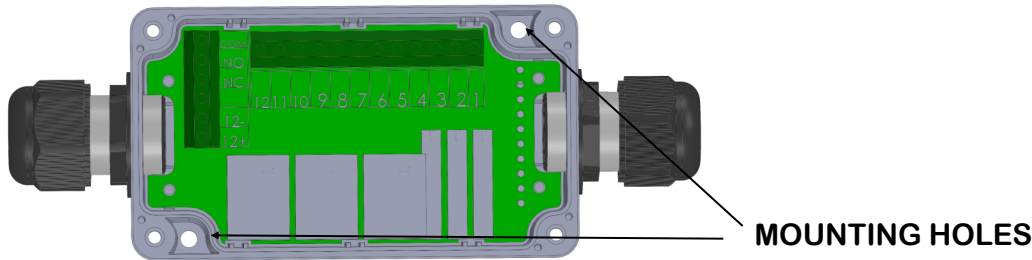

KP600 CONTROL PANEL INSTALLATION

1. The KP600 is the remote panel designed for control of the MK60DP/K60DP with the Electric Filter Switch (EFS). This panel allows the operator to have both water and high vacuum (filter clogging) warning with warning lights and an audible tone, remote filter switching, mute control and can arm the filter to automatically switch filters when an alarm is set. The panel should not be exposed to outside elements and must be mounted inside. Make sure the surface is flat, easily accessible and not in an area that will be bumped, kicked or objects placed on it. Determine that when routing wire from the KP600 panel to the interface box, it can be done easily with minimal obstructions.
2. The cutout template is only a guide. When printing out the KP600 template on PAGE 13 make sure the printer settings are set to 100% scale and use the document margins. After printing, measure the template and confirm the template is to scale. The final drill and cut dimensions are the installers responsibility to check.
3. Temporarily install the KP600 panel and secure with #6 flat screws. Make sure the panel is flat and the screws fit flush, then remove panel for wiring.

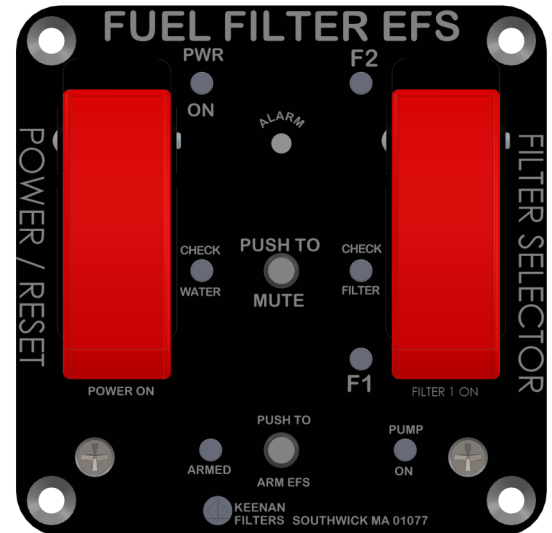

KP600 CONTROL PANEL

GSM INTERFACE (optional)

1. The auxiliary connections provide a normally open “NO” or normally closed “NC” contact, with a common connection “COM”. The connections are intended for the KTI GSM communicator. This system will warn the operator if the filter is clogging or water is present via a message sent on either a cell phone or by email. This system also allows the customer to turn on a device remotely from a mobile device or computer. Please refer to the GSM installation guide for the interface wiring.

1

2

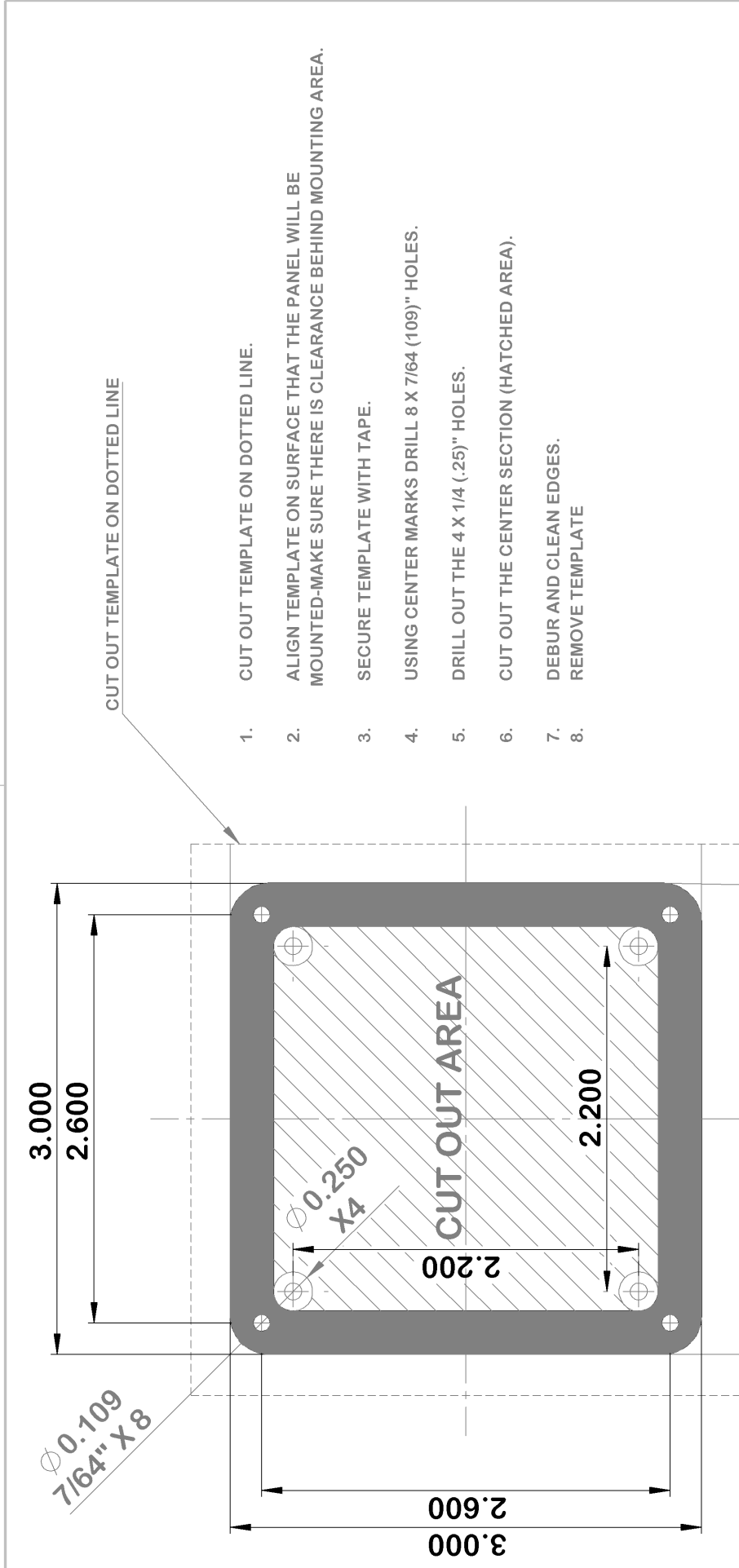

CUT OUT TEMPLATE ON DOTTED LINE

B

B

1. CUT OUT TEMPLATE ON DOTTED LINE.
2. ALIGN TEMPLATE ON SURFACE THAT THE PANEL WILL BE MOUNTED-MAKE SURE THERE IS CLEARANCE BEHIND MOUNTING AREA.
3. SECURE TEMPLATE WITH TAPE.
4. USING CENTER MARKS DRILL 8 X 7/64 (109)" HOLES.
5. DRILL OUT THE 4 X 1/4 (.25)" HOLES.
6. CUT OUT THE CENTER SECTION (HATCHED AREA).
7. DEBUR AND CLEAN EDGES.
8. REMOVE TEMPLATE

**DO NOT SCALE WHEN PRINTING USE 1:1
MEASURE TEMPLATE BEFORE USING**

A

A

UNLESS OTHERWISE SPECIFIED:		NAME	DATE
DIMENSIONS ARE IN INCHES	DRAWN	AK	5/17/17
TOLERANCES:	CHECKED		
FRACTIONAL ±	ENG APPR.		
ANGULAR: MACH ± BEND ±	MFG APPR.		
TWO PLACE DECIMAL ±	Q.A.		
THREE PLACE DECIMAL ±	COMMENTS:		
INTERPRET GEOMETRIC TOLERANCING PER:			
MATERIAL			
FINISH			
NEXT ASSY	USED ON		
APPLICATION	DO NOT SCALE DRAWING		

TITLE:
KP600 TEMPLATE

PROPRIETARY AND CONFIDENTIAL
THE INFORMATION CONTAINED IN THIS DRAWING IS THE SOLE PROPERTY OF <INSERT COMPANY NAME HERE>. ANY REPRODUCTION IN PART OR AS A WHOLE WITHOUT THE WRITTEN PERMISSION OF <INSERT COMPANY NAME HERE> IS PROHIBITED.

SIZE DWG. NO. REV
A KP600CUTTEMP

SCALE: 2:1 WEIGHT: SHEET 1 OF 1

1

2

FIELD WIRING (with EFS) -continued

4. Connect the KP600 control panel to the wiring harness and also the 12 VDC circuit protected power. Inspect and recheck all connections, check that wire harness and connections are supported and away from hot or moving equipment.

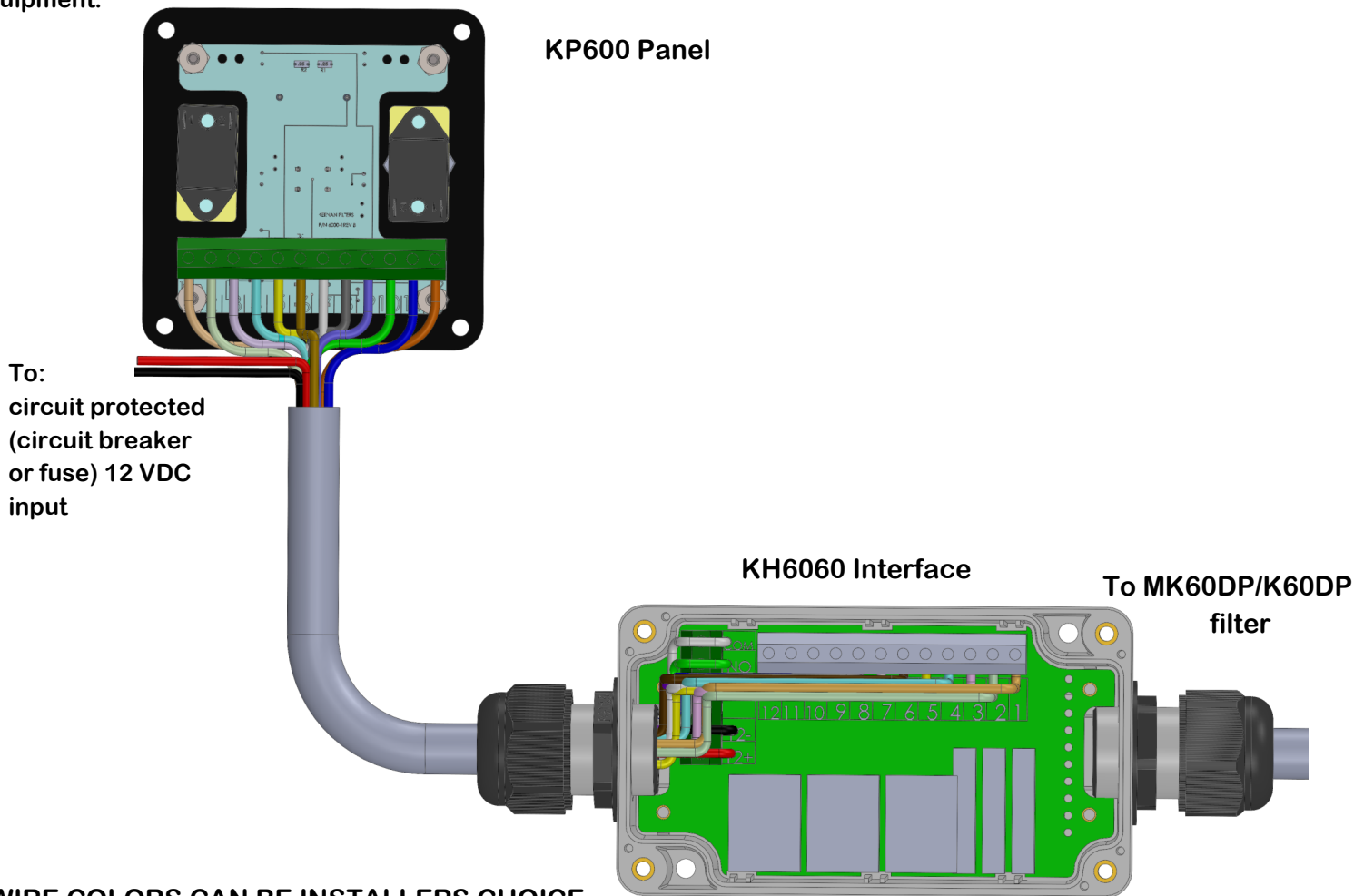

WIRE COLORS CAN BE INSTALLERS CHOICE

KP600 CONTROL PANEL CONNECTOR		KH6060 INTERFACE CONNECTION
1 YEL/WHT	CONNECTS TO	1 YEL/WHT
2 GRN/WHT	CONNECTS TO	2 GRN/WHT
3 BLUE/WHT	CONNECTS TO	3 BLUE/WHT
4 RED/WHT	CONNECTS TO	4 RED/WHT
5 YELLOW	CONNECTS TO	5 YELLOW
6 BROWN	CONNECTS TO	6 BROWN
7 WHITE	CONNECTS TO	7 WHITE
8 GREY	CONNECTS TO	8 GREY
9 PURPLE	CONNECTS TO	9 PURPLE
10 GREEN	CONNECTS TO	10 GREEN
11 DARK BLUE	CONNECTS TO	11 DARK BLUE
12 ORANGE	CONNECTS TO	12 ORANGE

CIRCUIT PROTECTED 12 VOLT SUPPLY		KH6060 INTERFACE CONNECTION
+12 RED	CONNECTS TO	+12
-12 BLACK	CONNECTS TO	-12

WARNING: REVERSE POLARITY MAY DAMAGE INTERNAL CIRCUITS

MAX CURRENT 2.3 AMPS- WIRE RUN SHOULD BE LESS THAN 15 FEET, IF LONGER USE A LOWER WIRE GAUGE CONDUCTOR AND TERMINAL BLOCK.

MK60DP TECHNICAL SPECIFICATIONS

Height	12.83" (32.5 cm)
Width	14.64" (37 cm) filter 12.75" (32.3 cm) mount panel
Depth	7.04" (17.9 cm)
Service Clearance	5" (12.7 cm) above 2" (5.1 cm) below
Weight	19.2lbs (8.7 kg)
Inlet and out ports	#10 Orb 7/8-14 or 1/2" NPT
Fuel	Diesel
Max Fuel Flow	60 gph (227 lt/h)
Max Operating Pressure	30 psi (2.1 bar)
Normal Operating Vacuum	0-6 in Hg (20 kPa)
Vacuum Alarm	8" + 2" in Hg (27 ± 7 kPa)
Bowl Water Alarm Capacity	5.5 oz. (163 ml)
Water Removal	99%
Voltage	12 VDC <i>Use 24v to 12v inverter for 24v systems</i>
Current Draw- Standby Warning EFS CYCLE Pump	76 ma 175 ma 300 ma 2.3 amps max
Circuit Protection	5 amp
Pump Psi Flow Duty Life Run dry	Walbro FRB13-2 6.0 to 8.0 psi (.41 - .55 bar) 60gph (227 lt/hr) 18000 + hrs Four (4) hours
<i>Recommended</i> Replacement elements -Racor® 	2 micron 2010SM-OR 10 micron 2010TM-OR 30 micron 2010PM-OR
<i>Recommended</i> 2 x 12 MM BUNA O-RING (T-Handle)	KTI P/N KAOR2MM12

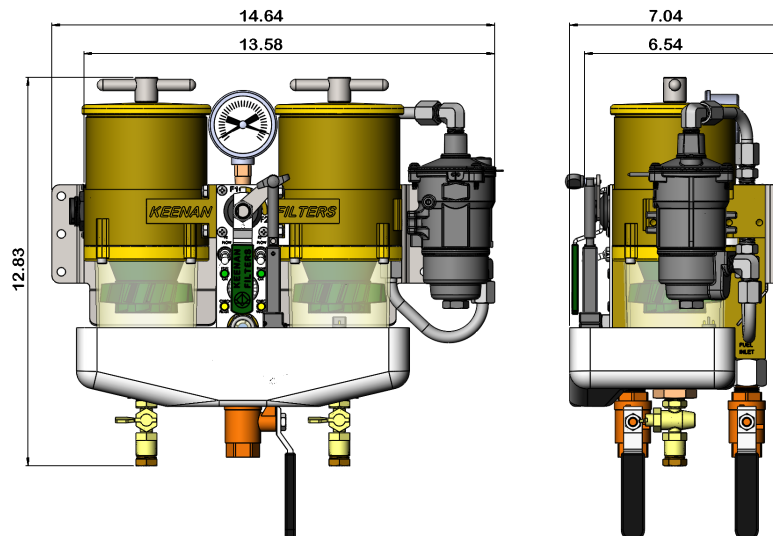

POST INSTALLATION

NOTE: Before servicing the filter, re-check all connections for security. Check that fuel lines are supported and will not interfere with other equipment or be near sharp objects, moving or hot equipment.

MK60DP FILTER INITIAL SERVICING

1. Make sure filter drain valves are closed.
2. Remove both F1, F2 filter T-handle & lid assembly.
3. Slowly pour clean diesel fuel into each filter until full. Stop filling if leaks are noticed.
4. Clean T-Handle threads and lubricate T-handle threads, T-handle O-rings (2ea) and lid square O-ring with clean engine oil. Make sure lid O-ring is seated in its groove and not twisted. Make sure lid O-ring mating surface is clean on the element housing.
5. *Care should be taken not to damage the return tube inlet when installing the T-handle.* Carefully insert T-Handle and begin threading into the return tube. Tighten until the lid bottoms and a resistance is felt. Continue to tighten an additional 1/4 turn to seat O-ring.

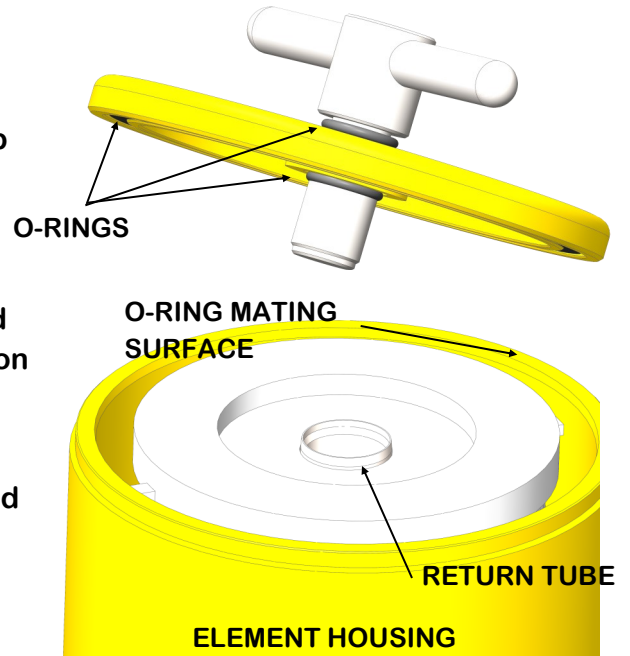

FUEL SYSTEM BLEEDING

Fuel system bleeding is removing the air out of the fuel system from the fuel tank pickup to the engine secondary filter. It is the operators choice on how to bleed the system. The steps below show some simple methods to bleed the system.

1. The above step of filling the filter with fuel helps with the initial start up, but can be also done by just turning on the pump and opening the bleed valve (T-handle and lid must be installed). The pump will start to draw a vacuum that will pull fuel from the tank and the filter bowl will start to fill. Once the bowl is full you will hear the pump change its tone which means fuel is entering the pump. Looking at the flow site below the selector handle, monitor the fuel in site glass, it will look foamy and as the air and fuel is bled back to the tank, the fuel will have less and less air. It will eventually become clear fuel. Let the pump run for several minutes to remove any residual air. Switch to the opposite filter by rotating the selector handle and perform the same bleeding as the first filter. Turn off pump and close the bleed valve (handle is horizontal).

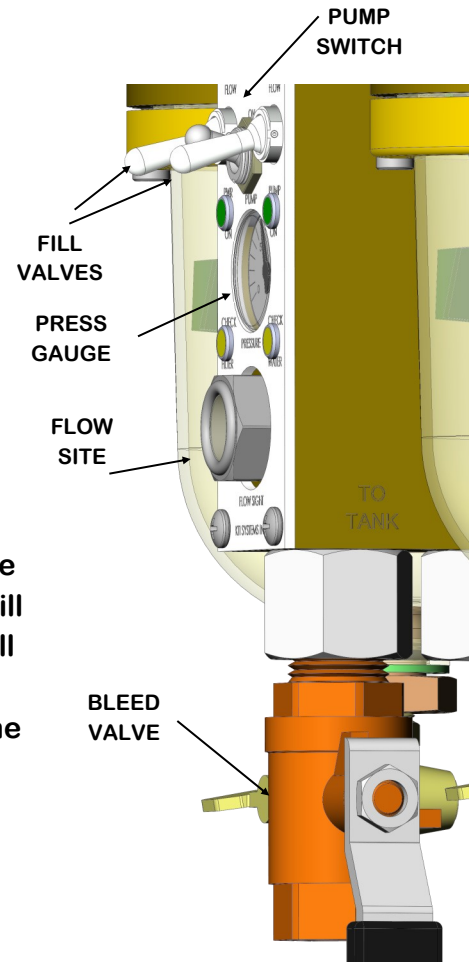

Continued next page

BLEEDING - continued

2. Next check and top off the filters by removing the T-handle and lid assembly of the OFFLINE filter, check to see if the bowl is full, if the fuel level is low perform the following steps.
 - A. Make sure both fill valves are in the closed position, bleed valve is closed (handle horizontal) and pump switch is off.
 - B. Turn on pump switch and observe pressure gauge is showing pressure (5-9 psi).
 - C. Momentarily open fill valve for the offline filter and close when the fuel level is close to the top, be careful not to overfill. Install T-handle lid assembly.
 - D. Using the selector handle switch to the opposite filter and perform the same steps to that filter.
 - E. Turn off pump and position the selector handle to the primary filter F1 (F1 filter provides water detection).
3. Next bleed the air out from the K60DP to the engine fuel system, using the fuel pump to provide both flow and pressure makes bleeding simple and quick. Follow the engine manufactures procedures for bleeding the engine fuel system.

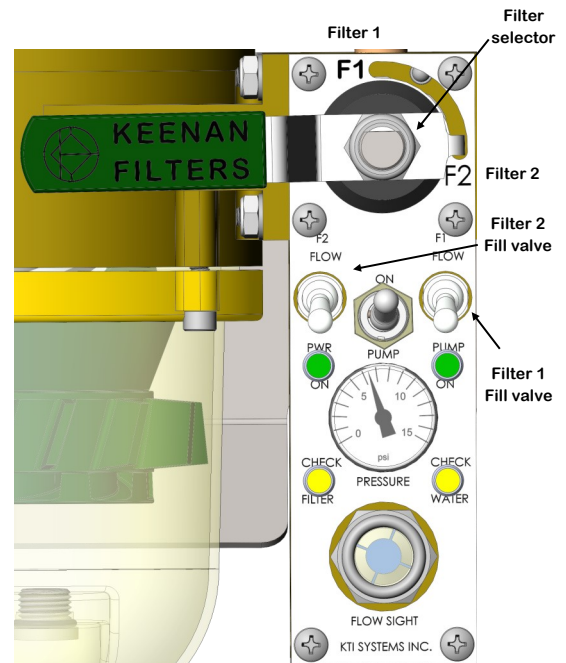

OPERATIONAL TEST

1. Position the filter handle to F1 and turn on power to the MK60DP/K60DP filter. There will be a momentary 1-2 second pulse tone and the "CHECK WATER" LED will illuminate. Next perform a normal engine start and warm up for 5 minutes. Check for leaks.
2. With the engine at idle speed, close the fuel inlet shut off valve and monitor the vacuum gauge for a steady increase in vacuum. Normally around 6" in Hg or 8" \pm 2" in Hg, the "CHECK FILTER" LED will illuminate and the audible pulse tone will sound. Press the mute switch on the KP300 or KP600 panel to mute the tone.
3. Shut down the engine and monitor the vacuum gauge needle. It should remain at the setting it was showing when the engine was shut down. If there is an air leak between the shut off valve and the engine lift pump, the gauge needle will move towards zero. Recheck all connections if a leak is detected and re-test. (A large leak could show up within 5 minutes, slower leaks will take more time) Perform the same test to filter F2.
4. The same test can be used to check the fuel systems integrity from the fuel tank shut to the engine by using the tank shut off instead of the filter inlet valve.
5. If satisfied with the operational test, open the fuel inlet shut off valve and operate the engine at idle for a few minutes. Next check the system for leaks and operation under normal engine operation between idle and full power. A normal vacuum reading should read below 3" in Hg at all power settings with a clean filter and full tanks. When satisfied with the engine operation test, perform the normal engine shutdown.
6. The OPERATIONAL TEST is a great way to check your system for integrity and warning. You can perform the test after maintenance has been completed or during scheduled inspection checks.

FILTER ELEMENT REPLACEMENT

SUGGESTED TOOLS AND SUPPLIES

- Replacement element 
- Clean diesel fuel
- Shop towels
- Suitable container for old filter element and to drain filter bowl.

ELEMENT REMOVAL

1. Engine can be on while changing the offline filter element.
2. Using the filter selector switch the dirty filter offline.
3. Remove lid assembly by rotating the T-handle in a counter clockwise rotation.
4. Holding the bail handles on either side of the element, slowly pull upward with a twisting motion. Place old element in suitable container.
5. Inspect filter bowl for contaminants or water. If needed, position suitable container under the bowl drain valve, remove drain plug and open drain valve to drain out the contaminants. Close valve and reinstall drain plug.
6. Remove new element from packaging. Bend bail handles upward (this will help when removing the element), slide element on to return tube until it bottoms.
7. Slowly fill filter with clean fuel to the top this can be accomplished by turning on the fuel pump and momentarily opening the filter fill valve. Turn off pump when done.
8. Inspect the three filter lid O-rings for nicks, cuts or deformity. If needed, replace the O-rings. (NOTE: the replacement element comes with the standard large square O-ring and a small red O-ring. Use the red O-ring in the upper position on the T-handle shaft and a new KAOR2MM12 (2 x 12 mm Buna) in the lower position. If a new lower O-ring is not available, use the better of the 2 remaining O-rings in the bottom position. When replacing the large square O-ring make sure it is not twisted in its groove.
9. Clean the T-handle threads and upper surface of the element housing where the square O-ring seats. Lubricate the O-rings and T-handle threads with clean engine oil.
10. Take care when threading the T-handle into the return tube. Tighten the T-handle finger tight until the lid bottoms and high resistance is felt. Continue to tighten an additional 1/4 turn to seat O-rings. NO TOOLS
11. Clean fuel from the filter spill pan (if present) and surrounding area.
12. System bleeding will most likely not be needed because the only air to enter the system was in the filter housing. When filling the filter the air is displaced by fuel.
13. Switch filter online and check for leaks.
14. When convenient perform the OPERATIONAL CHECK to test and leak check the filter. (See previous page)

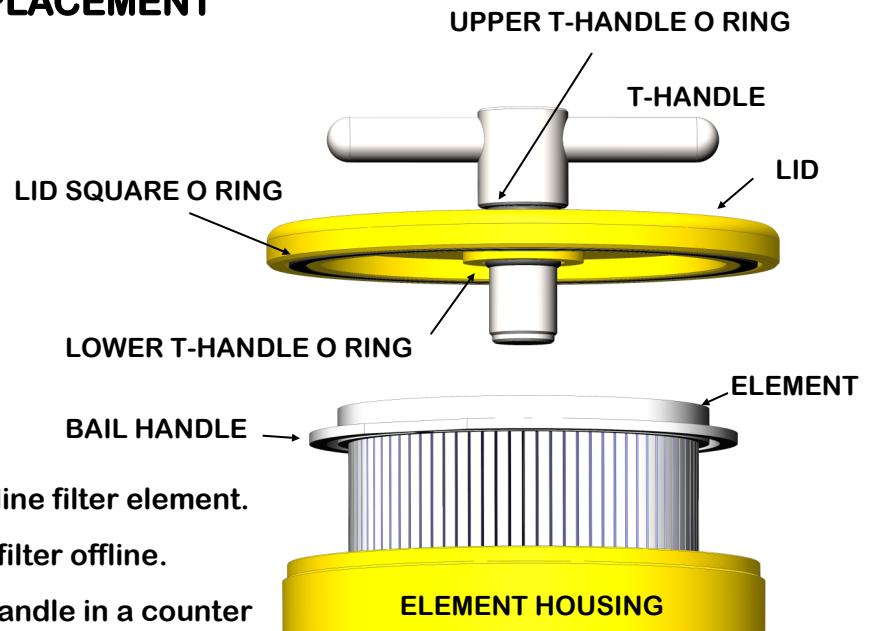

DRAINING WATER FROM BOWL

If water is in the online fuel bowl switch the filter OFFLINE.

GRAVITY METHOD

1. Remove the T-handle-lid assembly, remove the drain valve plug.
2. Position a container under the drain valve to catch the water and fuel .
3. Slowly open the filter drain valve until water is drained.
4. Slowly open the filter drain valve until water is drained.
5. Close drain valve and re-install drain valve plug.
6. Fill filter with clean fuel. Reinstall lid assembly. The filter is ready to be switched back on line when needed.
7. Perform OPERATIONAL TEST.

PRESSURE METHOD

(do not remove T-handle and lid assembly)

1. Make sure both fill valves and bleed valve are in the closed position.
2. Position a container under the drain valve to catch the water and fuel. Remove drain valve plug.
3. Turn fuel pump switch to “on”, this will pressurize the fuel system, momentarily open F1 or F2 fill valve for the filter with water in the bowl, now slowly open drain valve and until contaminants are drained.
4. Close drain valve, close fill valve turn off pump and install drain valve plug.
5. Perform OPERATIONAL TEST.

MAINTENANCE AND INSPECTION

- Routinely inspect the filter for leakage, damage or corrosion. Clean filter and wipe down with a light oil.
- Exercise selector handle between F1-F2 or operate EFS (electric filter switch) through a couple of cycles.
- Change the filter element minimally on an annual basis or when the vacuum reading starts to change.
- Perform the OPERATIONAL TEST before operation or during routine inspections. The OPERATIONAL TEST checks the warning system for operation and also the integrity of the fuel system for air leaks.

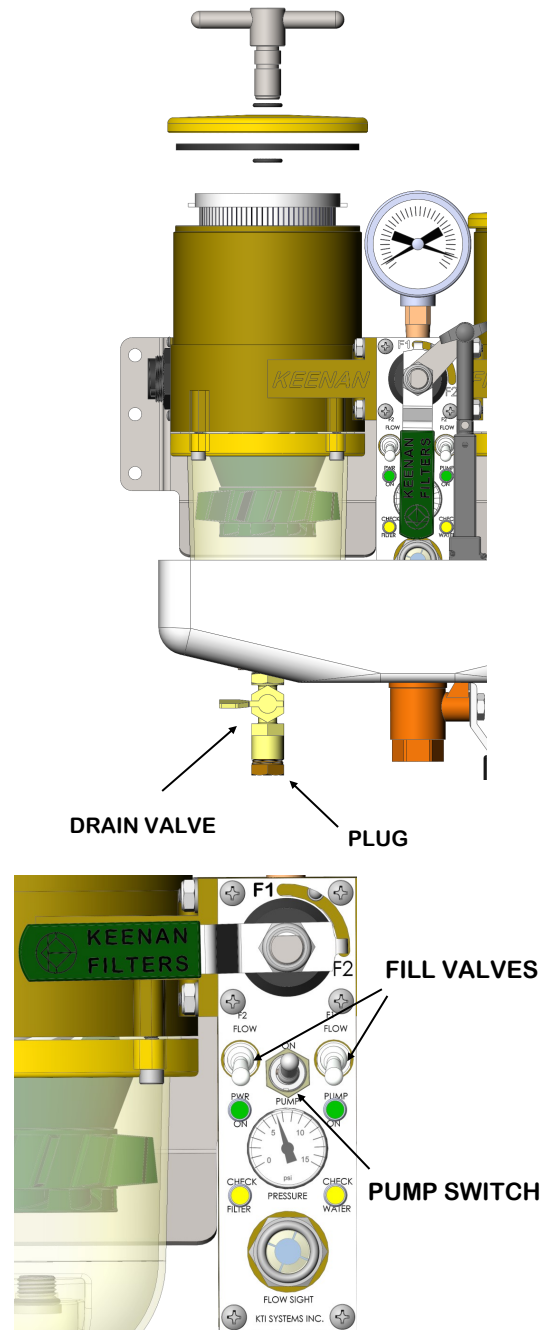

KP300 CONTROL PANEL OPERATION

The control panel will give the operator indication and audible warning if the filter is starting to clog (high vacuum) or more than 5.5 ounces of water is present in the online fuel bowl. The operator can MUTE the audible alarm so it is not distracting.

Normally a clogged filter or water warning will take many hours of operation to trip the alarm, so an engine shut down will not happen immediately when the alarm does sound. This gives the operator some time if needed, to prepare for shutting down the engine and servicing the filter.

Note: If the water alarm sounds after fueling or switching tanks the operator may need to shut down the engine quickly because of EXCESSIVE water contamination. Check the fuel bowl for a rising water level.

The system can be turned on or off from the panel using the power reset switch.

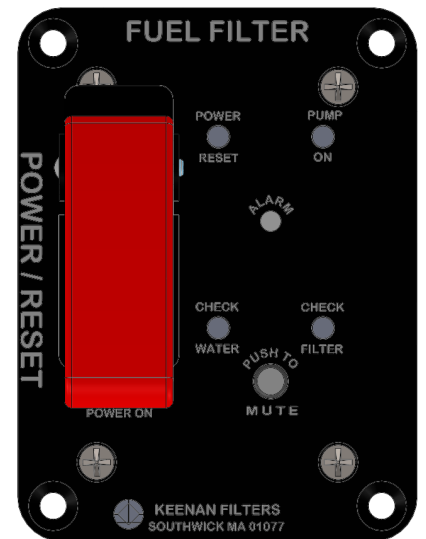

KP600 CONTROL PANEL OPERATION (for optional EFS)

The KP600 has the same filter warnings as the KP300. It also allows the operator to manually (electrically) switch between filter F1 and F2 by lifting the guard and selecting the filter. You can arm the system to automatically switch filters by pressing the ARM SWITCH (arm light will illuminate). When a warning is tripped the system will automatically switch filters.

PUMP ON - Indication that the fuel pump is in operation. (*Light is not used on the MK60D/K60D*) See the wiring diagram for information on connections if a pump is installed.

POWER / RESET - allows the operator to shutdown or reset the system.

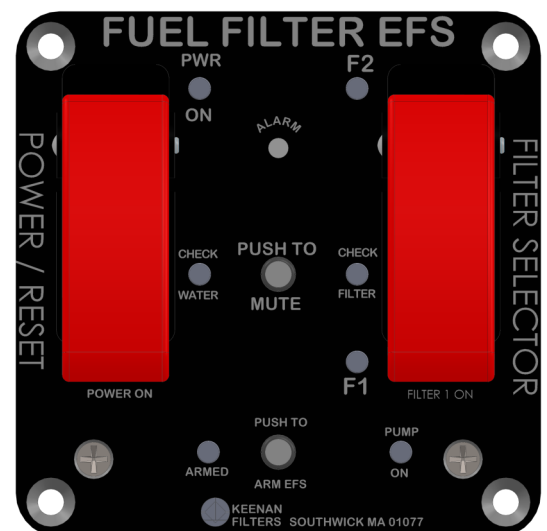

HOW IT WORKS

Once the system has been serviced and the operational test was completed it is ready to be used.

Make sure the filter is configured as follows:

- Pump switch off
- Fuel inlet shut off valve (SOV) open
- Filter selector on F1
- Drain valves closed
- Bleed (return) shut off valve (SOV) closed
- Vacuum gauge drag pointer set to “zero”

The Control Panel is configured as follows:

EFS armed (land based operations)– Normally armed - automatic filter switching when a clogged filter or water is detected on the online filter (F1)

EFS armed (marine operations) - Not recommended –crew should always be notified and make the filter switch.

System powered on

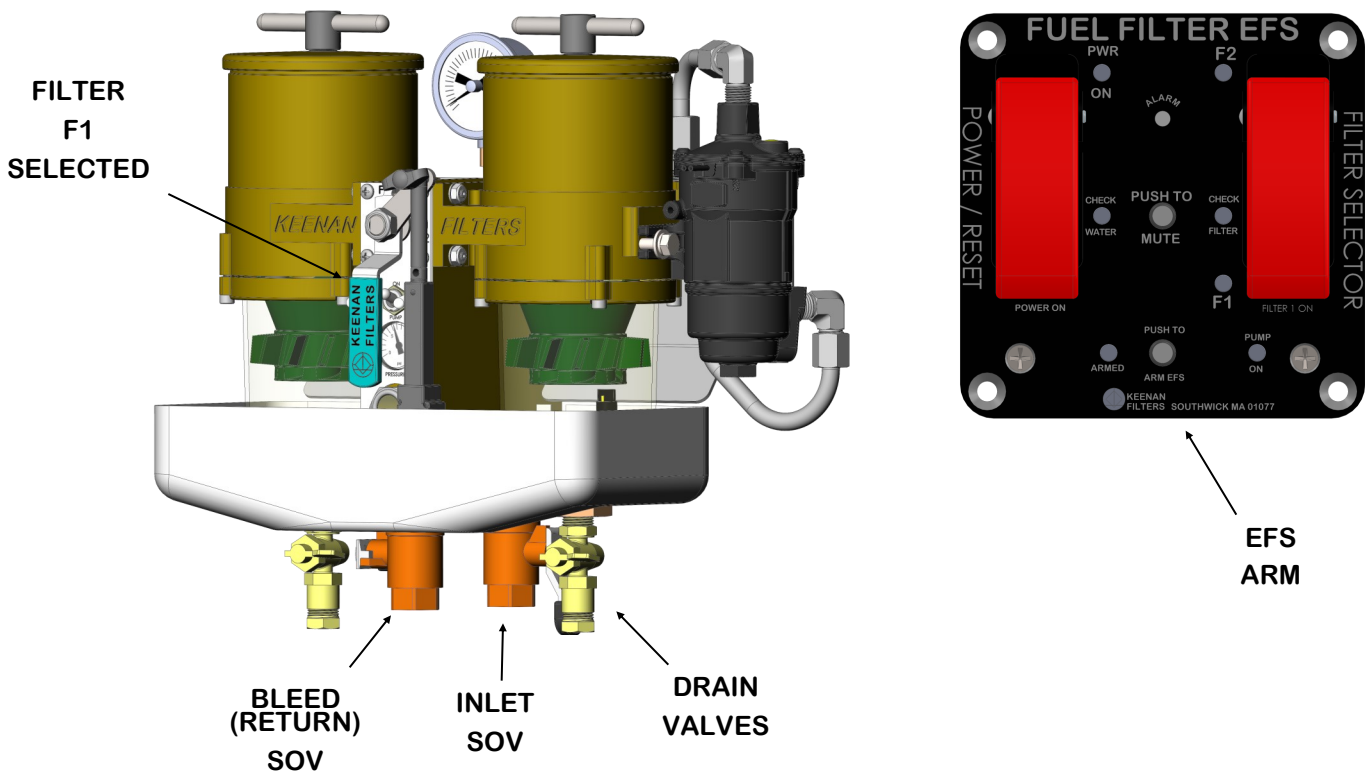

Normal operation should be on filter F1-this is where the water detector is located and the selector handle protects the pump and fill valve switches. When the online filter vacuum starts to increase or the alarm is sounded the operator should switch the dirty filter off line and go to filter F2.

If convenient change out or drain the F1 filter, fill with fuel. To leak check the off line filter turn on the pump and momentarily open the F1 fill valve to pressurize the filter and check for leaks, if ok and no leaks are noted, turn off pump and switch the F1 filter back on line.

FUEL POLISHING

Fuel polishing is the technical cleaning process used to remove or filter microbial contamination from oil and hydrocarbon fuel in storage. It is essentially the removal of water, sediment and microbial contamination from such fuels as [diesel](#), [red diesel](#) and [biodiesel](#). This fuel contamination, also known as 'fuel bugs' or 'diesel bugs' build up over time in stored fuels if they aren't tested and treated on a regular basis.

Fuel polishing is more effective when the contaminants are suspended or mixed in the fuel, so polishing just after or during refueling, during engine operation and during or after a boating trip is best.

To Polish: OPEN BLEED VALVE, next turn on the electric fuel pump. Now the fuel will be pulled from the fuel tank through the online filter and ported back to the tank, it is that easy.

The rated fuel flow of the MK60DP is around 60 gallons per hour, so take the tank fuel quantity and multiply it by 3 then divide it by 60 and that will be a good rule of thumb of how long you should polish the fuel.

The F1 filter is the primary filter, so if the water or filter alarm is sounded, switch the F1 filter offline, drain and service as needed, then switch the F1 back online.

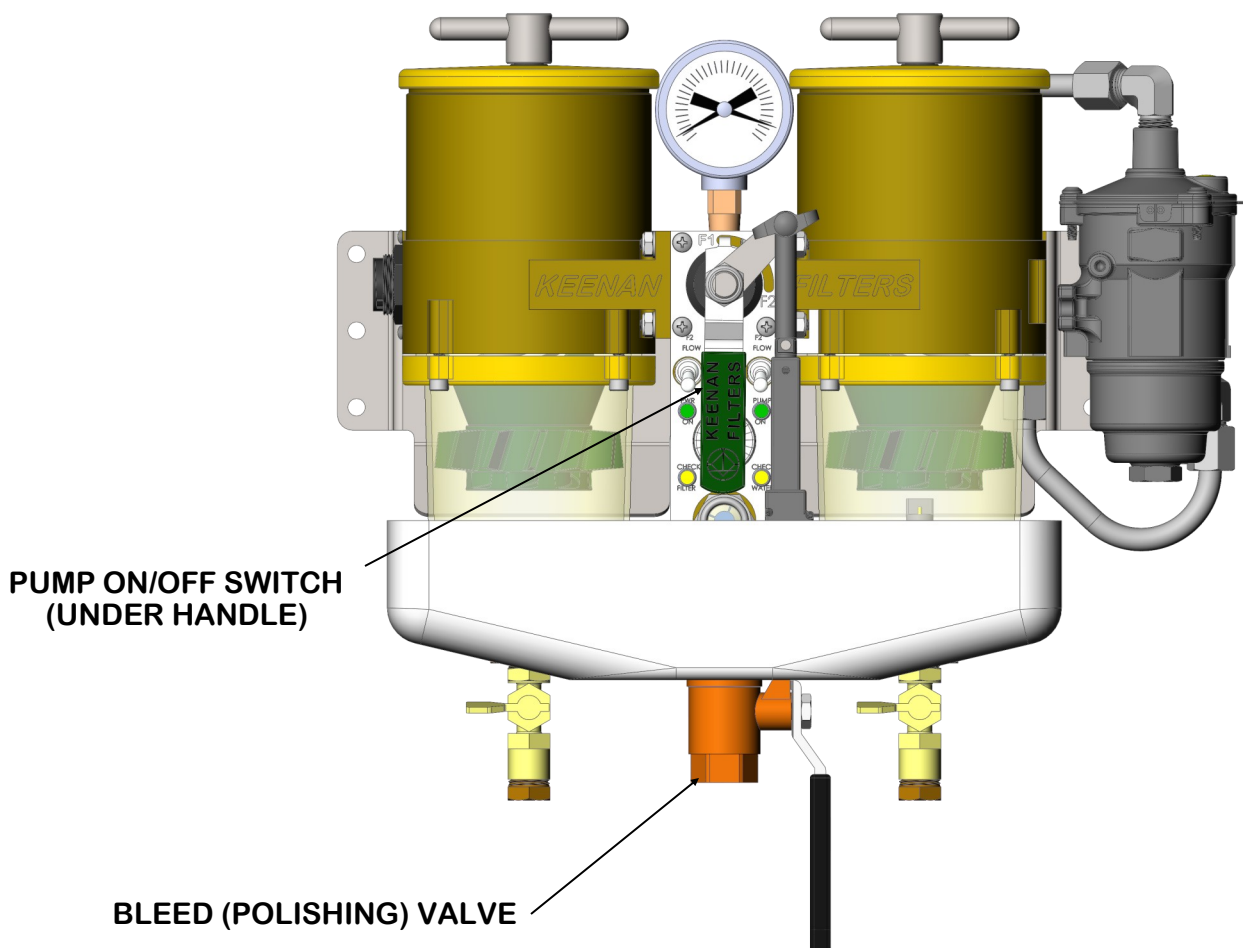

LIMITED WARRANTY

Thank you for purchasing a product from K.T.I. Systems, Inc. of Southwick, Massachusetts.

All products manufactured by K.T.I. are subject to the following Limited Warranty.

Limited Warranty. K.T.I. warrants and guarantees only to the original purchaser that the product is free from defects of materials and workmanship in the manufacturing process for the period of one year from the date of purchase of a new K.T.I. product.

This Warranty does not apply to special order items and this Warranty does not apply to renovated, retrofit or modified products, whether or not they originated with K.T.I. and whether or not they were retrofit by the original owner.

This Warranty does not apply to products installed in watercraft for racing or competition.

This Warranty shall be inapplicable to any product not properly installed and not properly used by the purchaser or to any product damaged or impaired by external forces.

This Warranty does not cover any product for which applicable proof of purchase date, installation date and watercraft mileage at the time of installation is not presented.

This Warranty does not cover any issues that are considered normal maintenance and which are customarily replaced, cleaned or adjusted as normal owner maintenance, unless they are defective in material or factory workmanship.

Process. A product claimed to be defective must be returned to the place of purchase. K.T.I. at its sole option shall replace the defective product with a comparable new product or repair the defective product in the event that it qualifies under this Warranty.

LIMITATION OF LIABILITY

To the extent that this Warranty is available on this product, K.T.I. shall have no liability whatsoever for incidental or consequential damages flowing from the use of any defect product or by reason of the failure of any product. K.T.I. specifically disavows all express or implied warranties of fitness for a particular purpose, warranties of description, and warranties of merchantability.

Product Warning. This product and its use may be considered inherently dangerous. Failure of the product, improper selection of the product or improper use of the product or related products may cause death, personal injury and property damage. K.T.I. disclaims any responsibility for any such injury or damage.

Indemnity. You agree to indemnify and hold K.T.I., its officers, directors, employees, agents, harmless from any and all claims, demands, lawsuits, liabilities and expenses arising out of or in connection with your use of the product and your breach or violation of any of the Terms of this Limited Warranty.

Legal Disclosure. The product is protected by United States Patents. "KEENAN FILTERS" is a registered trademark of K.T.I. Systems, Inc. The materials presented herewith, including this Limited Warranty, are protected by the Copyright laws of the United States of America. You may not copy or reverse engineer our product. Your use of this product indicates that you have read this Limited Warranty and the Legal Disclosure and agree to comply herewith.

© 2017, K.T.I. Systems, Inc.

All rights reserved.